

SHAPE

- Oval

SIZE

- Length: 490 mm, Width: 401 mm, Height: 900 mm

MATERIAL

- QUARRYCAST™

WEIGHT

- 20.6kg

INSTALLATION TYPE

- Freestanding

FINISH

- Gloss White, Matt White

DRAIN

- Hidden freeflow drain

WARRANTY

- 25 years residential
- 8 years commercial
- Visit www.vandabaths.com for further information

SPECIFICATIONS



SEROSTM49

Freestanding Podium Basin

MODELS: FS-SER-49-NO,
FS-SER49M-SM-NO

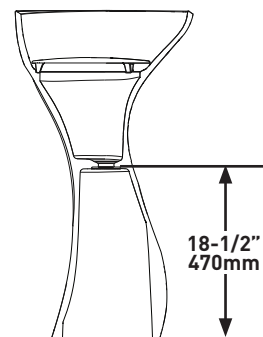
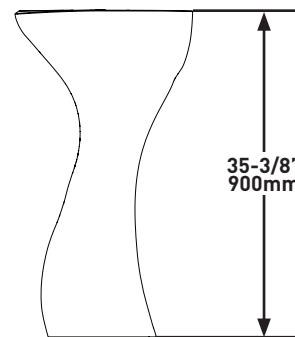
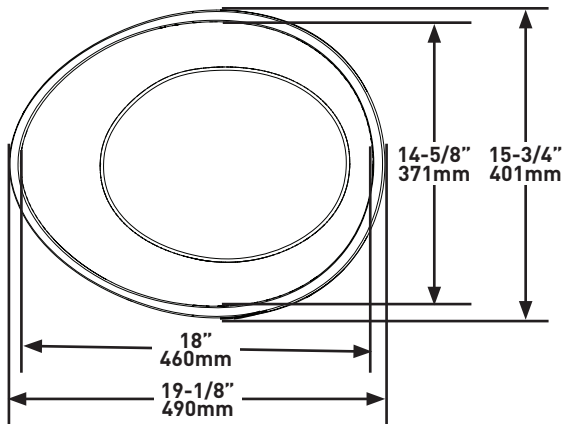

For care and cleaning, product warranty, and additional information contact:

US Customers

U.S.A.
houseofrohl.com/support
1-800-777-9762

Canadian Customers

QUEBEC / MARITIMES / WESTERN CANADA
QUÉBEC / MARITIMES / OUEST CANADIEN
QUEBEC / MARITIMOS / CANADA OCCIDENTAL
houseofrohl.ca/support
1-866-473-8442

EMEA Customers

vandabaths.com
+44 (0) 1952 221 100