

DESCRIPTION

- Universal bath waste kit

STANDARDS

- WMTS 040 (2022)

WARRANTY

- Bath waste products have been tested to a load rating of 100kg. Any load above 100kg may affect the product warranty
- Visit www.vandabaths.com for further information

SPECIFICATIONS

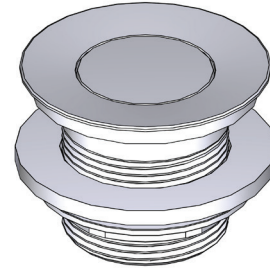

Drain Kit

MODELS: K-12 Series

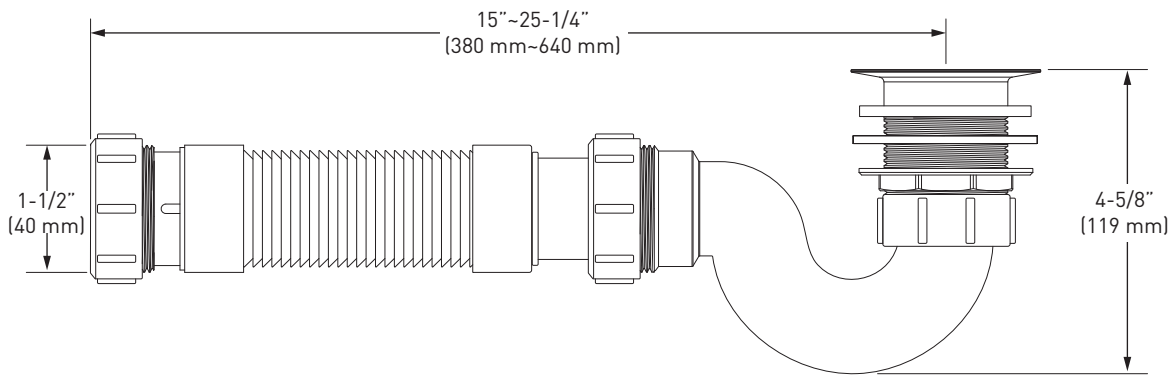
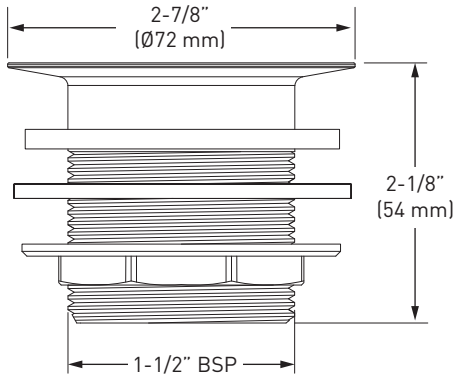

For care and cleaning, product warranty, and additional information contact:

US Customers

U.S.A.
houseofrohl.com/support
 1-800-777-9762

Canadian Customers

QUEBEC / MARITIMES / WESTERN CANADA
 QUÉBEC / MARITIMES / OUEST CANADIEN
 QUEBEC / MARITIMOS / CANADA OCCIDENTAL
houseofrohl.ca/support
 1-866-473-8442

EMEA Customers

UNITED KINGDOM
www.houseofrohl.uk
 01952 221100