

HOUSE OF ROHL

PRESENTS

victoria ⊕ albert

# SEROS COLLECTION



EN

WATER IN SCULPTED FORM.

Seros is a unique collaboration between Victoria + Albert and British sculptor, Sophie-Elizabeth Thompson. Inspired by Sophie's sculptures, the collection embodies the energy and movement of water through organic, fluid forms. Each piece in the collection is extraordinary and beautiful in itself.

SOPHIE-ELIZABETH THOMPSON AND THE ORIGIN OF SEROS.

Sophie-Elizabeth Thompson is a British artist working in Barcelona. Her creative work is exhibited all over the world, in galleries and public spaces. She says that her best work comes from 'the feeling of absolute calm when I'm creating in my studio - whether I'm drawing or carving, I am not thinking about anything and feel completely at peace and happy'. This sense of tranquillity is reflected in the Seros designs, making it the perfect collection for a spa or wellness bathroom.

DE

WASSER IN SKULPTURFORM.

Seros ist eine einzigartige Zusammenarbeit zwischen Victoria + Albert und der britischen Bildhauerin Sophie-Elizabeth Thompson. Die von Sophies Skulpturen inspirierte Kollektion verkörpert durch ihre organischen, fließenden Formen die Energie und Bewegung des Wassers. Jedes Stück der Kollektion ist für sich allein außergewöhnlich und wunderschön.

SOPHIE-ELIZABETH THOMPSON UND DIE URSPRÜNGE VON SEROS.

Sophie-Elizabeth Thompson ist eine britische Künstlerin, die in ihrem Studio in Barcelona arbeitet. Ihre kreative Arbeit findet ihren Ausdruck sowohl in der Skulptur als auch in Gemälden. Ihr künstlerisches Schaffen ist eine natürliche, intuitive Reaktion auf ihre Umwelt, und sie lässt sich sowohl von natürlichen als auch von menschengemachten Formen anregen. Es sind die Details, die sie inspirieren – aus dem Zusammenhang gerissene Elemente des Ganzen, die auf zarte Knochenformen und industrielle architektonische Strukturen verweisen, fließende Formen und der häufig ignorierte negative Raum zwischen Objekten.

ES

EL AGUA EN FORMA DE ESCULTURA.

Seros es una colaboración exclusiva entre Victoria + Albert y la escultora británica Sophie-Elizabeth Thompson. La colección, inspirada en las esculturas de Sophie, plasma la energía y el movimiento del agua a través de formas orgánicas y fluidas. Cada pieza de la colección es extraordinaria y bella por sí misma.

SOPHIE-ELIZABETH THOMPSON Y EL ORIGEN DE SEROS.

Sophie-Elizabeth Thompson es una artista británica que trabaja desde su estudio en Barcelona. Su obra creativa se expresa tanto en escultura como en dibujo. Su producción artística es la respuesta intuitiva natural al mundo que la rodea, y se inspira tanto en las formas naturales como en aquellas creadas por el hombre. Los detalles la inspiran: los elementos del todo, sacados de contexto, que pueden hacer referencia a unas delicadas formas óseas, las estructuras arquitectónicas industriales, las formas fluidas y el espacio negativo entre los objetos, a menudo ignorado.



FR

### L'EAU SOUS FORME SCULPTÉE.

Seros est une collaboration unique entre Victoria + Albert et la sculptrice britannique Sophie-Elizabeth Thompson. La collection s'inspire des sculptures de Sophie pour personnifier l'énergie et le mouvement de l'eau par des courbes organiques et fluides. Chaque pièce de la collection offre sa propre beauté extraordinaire.

### SOPHIE-ELIZABETH THOMPSON ET LES ORIGINES DE SEROS.

Sophie-Elizabeth Thompson est une artiste britannique qui travaille dans son studio installé à Barcelone. Elle exprime sa créativité à travers la sculpture et le dessin. Son œuvre artistique est une réaction intuitive au monde qui l'entoure et elle s'inspire aussi bien des formes naturelles qu'artificielles. Ce sont les détails qui l'intéressent : des éléments tirés d'un tout, hors contexte, qui rappellent les formes d'une délicate ossature, les structures d'une architecture industrielle, la fluidité d'une courbe ou, trop peu remarqué, l'espace négatif entre des objets.

IT

### ACQUA IN FORMA SCULTOREA.

Seros è il risultato di una collaborazione esclusiva tra Victoria + Albert e la scultrice britannica Sophie-Elizabeth Thompson. La collezione, ispirata alle sculture di Sophie, incarna l'energia e il movimento dell'acqua attraverso forme organiche e fluide. Ogni pezzo della collezione si distingue per la sua straordinarietà e bellezza unica.

### SOPHIE-ELIZABETH THOMPSON E LA NASCITA DI SEROS.

Sophie-Elizabeth Thompson è un'artista britannica che esercita la propria professione nel suo studio di Barcellona. La sua creatività si esprime sia nella scultura che nel disegno. La sua produzione artistica rappresenta una risposta spontanea e istintiva al mondo circostante, traendo ispirazione sia dalle forme naturali che da quelle artificiali. I dettagli sono la sua fonte di ispirazione; sono gli elementi singoli che, quando estratti dal contesto, richiamano le forme delicate delle ossa, le strutture architettoniche industriali e le linee fluide, così come lo spazio negativo spesso trascurato tra gli oggetti.

NL

### WATER IN GEBEELDHOUWDE FORM.

Seros is een unieke samenwerking tussen Victoria + Albert en de Britse beeldhouwer Sophie-Elizabeth Thompson. De collectie is geïnspireerd op Sophie's sculpturen en belichaamt de energie en beweging van water door organische, vloeiende vormen. Elk product in de collectie is bijzonder en mooi op zichzelf.

### SOPHIE-ELIZABETH THOMPSON EN DE OORSPRONG VAN SEROS.

Sophie-Elizabeth Thompson is een Britse kunstenaar die in Barcelona werkt. Haar werk wordt over de hele wereld tentoongesteld, in galerieën en openbare ruimtes. Ze zegt dat haar beste werk voortkomt uit 'het gevoel van absolute rust wanneer ik aan het creëren ben in mijn atelier - of ik nu teken of beeldhouw, ik denk nergens aan en voel me volledig in vrede en gelukkig'. Dit gevoel van rust wordt weerspiegeld in de ontwerpen van Seros, waardoor het de perfecte collectie is voor een spa- of wellnessbadkamer.

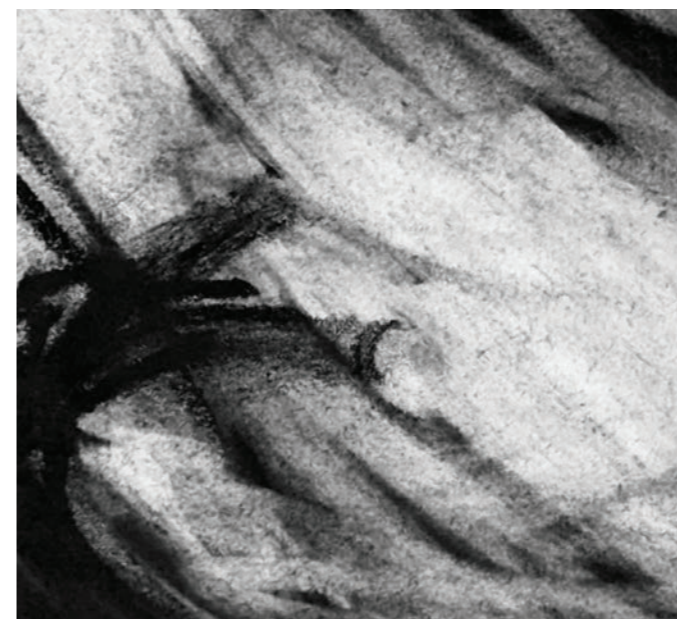
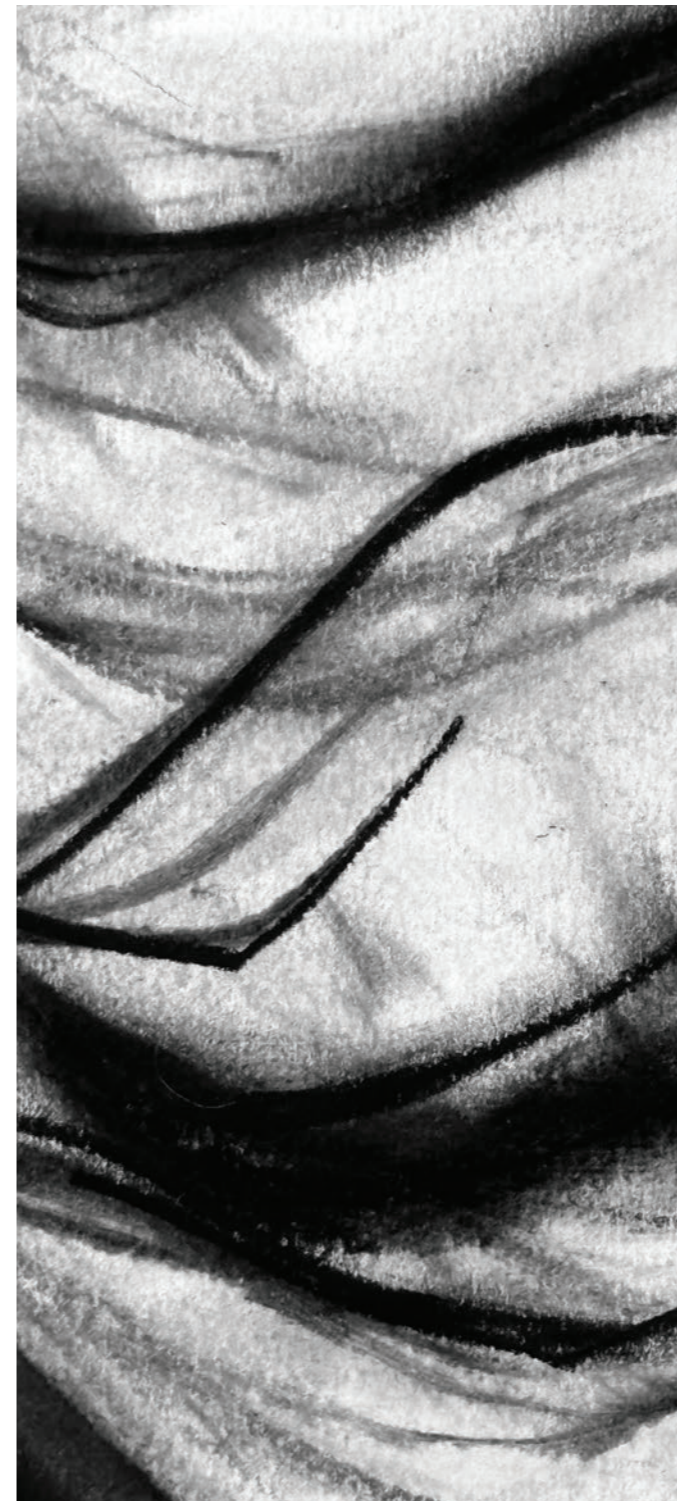

# Seros Collection



**Seros 1650**  
SE1-N-SW-NO / SE1M-N-SM-NO

**Seros 1800**  
SE2-N-SW-NO / SE2M-N-SM-NO



**Seros 55**  
VB-SER-55-IO / VB-SER55M-SM-IO



**Seros 49**  
FS-SER-49-NO / FS-SER49M-SM-NO

# Seros 1650



# Seros 1800

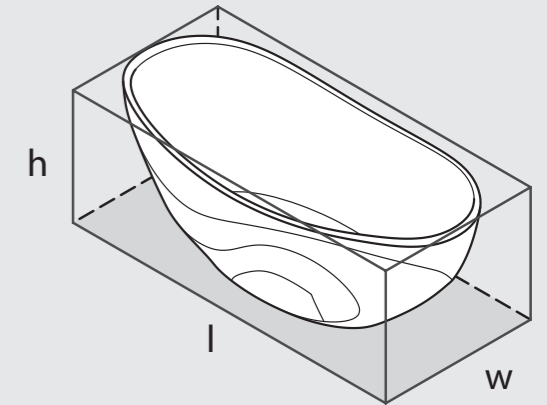
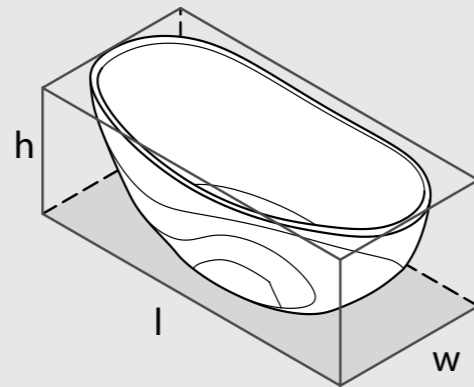

## QUARRYCAST™

### SE1-N-SW-NO

Gloss / Glänzend / Brillante / Brilliant / Lucido / Glanzend

### SE1M-N-SM-NO

Matt / Matt / Mate / Matt / Opaco / Mat

(L) 1647mm / 64<sup>7</sup>/<sub>8</sub>"

(W) 763mm / 30"

(H) 598mm / 23<sup>1</sup>/<sub>2</sub>"

✓ K-12-xx / K-17-xx / K-36-xx / K-40-xx

KG 86

↑ 348

## QUARRYCAST™

### SE2-N-SW-NO

Gloss / Glänzend / Brillante / Brilliant / Lucido / Glanzend

### SE2M-N-SM-NO

Matt / Matt / Mate / Matt / Opaco / Mat

(L) 1776mm / 69<sup>7</sup>/<sub>8</sub>"

(W) 766mm / 30<sup>1</sup>/<sub>8</sub>"

(H) 595mm / 23<sup>3</sup>/<sub>8</sub>"

✓ K-12-xx / K-17-xx / K-36-xx / K-40-xx

KG 93

↑ 380

Weight  
Gewicht  
Peso  
Poids  
Peso  
Capaciteit



Maximum litre capacity  
Maximale Kapazität (Liter)  
Capacidad máxima (litros)  
Capacité maximum (litres)  
Massima capacità' (litri)  
Maximale capaciteit (liter)



Bath  
Wanne  
Bañera  
Baignoire  
Vasca  
Bad



Waste kit options  
Ablauf-Optionen  
Opciones de desagüe  
Options de kit vidage  
Opzioni kit di scarico  
Afvoerkitopties



Weight  
Gewicht  
Peso  
Poids  
Peso  
Capaciteit



Maximum litre capacity  
Maximale Kapazität (Liter)  
Capacidad máxima (litros)  
Capacité maximum (litres)  
Massima capacità' (litri)  
Maximale capaciteit (liter)



Bath  
Wanne  
Bañera  
Baignoire  
Vasca  
Bad



Waste kit options  
Ablauf-Optionen  
Opciones de desagüe  
Options de kit vidage  
Opzioni kit di scarico  
Afvoerkitopties

# Seros 49

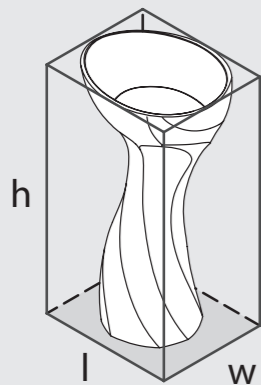

## QUARRYCAST™

### FS-SER-49-NO

Gloss / Glänzend / Brillante / Brillant / Lucido / Glanzend

### FS-SER49M-SM-NO

Matt / Matt / Mate / Matt / Opaco / Mat



(L) 489mm / 19¼"

(W) 401mm / 15¾"

(H) 900mm / 35⅝"

No waste kit required / Kein Ablauf-Set erforderlich  
 No necesita desagüe / Pas de vidage nécessaire  
 Non è necessario alcun kit di scarico / Geen afvoerkit vereist

Hidden freeflow drain  
 Wenn die Wand stoff vorsichtig von der Ventilbox entfernen  
 Drenaje de flujo libre oculto / Vidage à écoulement libre caché  
 Scarico a flusso libero nascosto / Verborgen afvoer met vrije doorstroming

# Seros 55

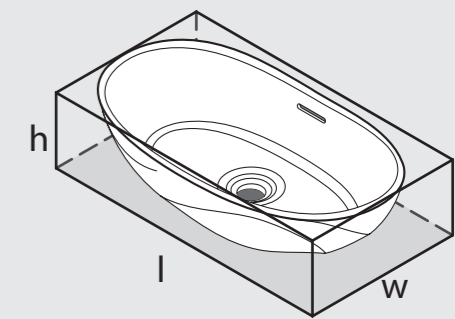

## QUARRYCAST™

### VB-SER-55-IO

Gloss / Glänzend / Brillante / Brillant / Lucido / Glanzend

### VB-SER55M-SM-IO

Matt / Matt / Mate / Matt / Opaco / Mat

(L) 548mm / 21⅝"

(W) 300mm / 11¾"

(H) 159mm / 6¼"

✓ K-22-xx / K-25-xx / K-28-xx



Weight  
Gewicht  
Peso  
Poids  
Peso  
Capaciteit

Basin  
Waschbecken  
Lavabo  
Vasque  
Lavabo  
Wasbak

Weight  
Gewicht  
Peso  
Poids  
Peso  
Capaciteit

Maximum litre capacity  
Maximale Kapazität (Liter)  
Capacidad máxima (litros)  
Capacité maximum (litres)  
Massima capacità\* (litri)  
Maximale capaciteit (liter)

Basin  
Waschbecken  
Lavabo  
Vasque  
Lavabo  
Wasbak

Waste kit options  
Ablauf-Optionen  
Opciones de desagüe  
Options de kit vidage  
Opzioni kit di scarico  
Afvoerkitopties

Internal overflow  
Integrierter Überlauf  
Rebosadero integrado  
Trop-plein intégré  
Trooppieno interno  
Geïntegreerde overloop

