

SHAPE

- Oval

SIZE

- Length: 1776 mm, Width: 766 mm, Height: 594 mm

MATERIAL

- QUARRYCAST™

DRAIN HOLE

- Centred

WEIGHT

- 93.1kg

CAPACITY

- 380L

INSTALLATION TYPE

- Freestanding
- Note:** All baths in Australia come standard without an overflow

FINISH

- Gloss White, Matt White

DRAIN SET

- Drain kit required, sold separately
- Recommended wastes: K-12, K-17

STANDARDS

- CSA B45.5:22, IAPMO Z124-2022

WARRANTY

- 25 years residential
- 8 years commercial
- Visit www.vandabaths.com for further information

SPECIFICATIONS



SEROST™ 1800

Freestanding Bath

MODELS: SE2-N-SW-NO, SE2M-N-SM-NO

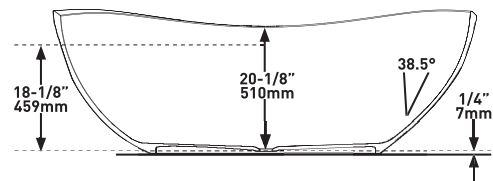
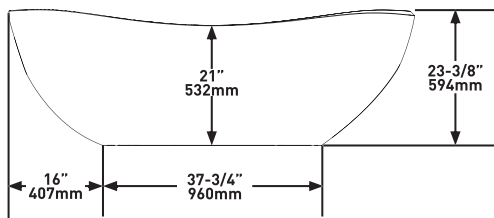
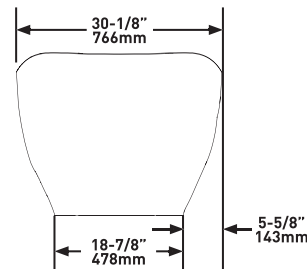
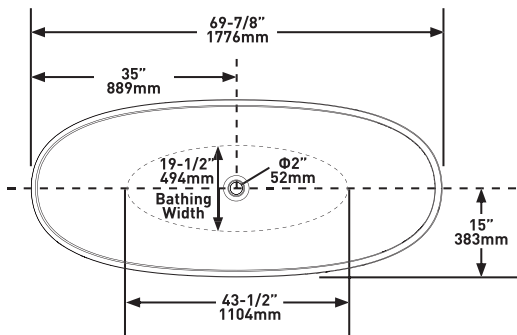

For care and cleaning, product warranty, and additional information contact:

U.S.A.
houseofrohl.com/support
 1-800-777-9762

Canadian Customers
 Quebec / Maritimes / Western Canada
 Québec / Maritimes / Ouest Canadien
 Quebec / Maritimos / Canada Occidental
 1-800-777-9762

EMEA Customers
vandabaths.com
 +44 (0) 1952 221 100